



E a s y n e t Co., L T D

AC/DC CONVERTER

SPECIFICATION FOR APPROVAL

Customer : _____

Part NO. : _____

Customer Approval NO. : _____

Model NO: EAS045Q120 ROHS : Yes

Description: 12V 450mA 5.4W Revision : 01

Issued Date: 2017/5/02 Certification : CE

CUSTOMER APPROVED

--	--	--

Remark:

- 1).Please approves and sign back to Easynet.
- 2).If there is on signing back, this Approval sheet will be regarded as being approved automatically once the first P.O of the model specified in the sheet is issued.

EASYNET Co., LTD

Add: GU-RO CHUNG-ANG YOOTONG CENTER, GA-DONG 3303, GU-RO, SEOUL, KOREA

Tel: 02-6679-5252

Fax: 02-6679-5253

http: //www.easy-net.kr

E_mail: kdh82@easy-net.kr

Contents

1. Description	04
2. Electrical.	04
2.1 Input Voltage(AC)	04
2.2 Input Frequency	04
2.3 Inrush Current	04
2.4 Input Current	04
2.5 Hold-Up time	04
2.6 Input wattage at output no-load / minimum-load condition	04
2.7 Efficiency	04
2.8 Safety Test	04
2.9 Output Voltage and Current (DC)	05
2.10 Ripple and Noise	05
2.11 Over-Shoot and under-shoot	05
2.12 Protection	05
2.13 Rise time	05
2.14 Output voltage Temperature Coeffiience	05
3. Environment	05
3.1 Temperature a. Operation	05
3.2 Humidity	06
3.3 Altitude	06
4. EMC	06
4.1 EMS	06
4.2 EMI	06
5. Reliability	06
5.1 Life	06
5.2 M.T.B	06
5.3 Temperature Rise	06
5.4 Burn-in	06
5.5 Vibration Test	06
5.6 Drop-test	06
6. Mechanical characteristics	07
7. Outline Dimensions	08
8. Label Diagram	09
9. Packing Drawing	10



Change List

ECN No.	REV	Revision Description	Date
1	01	NO SAMPLE	2017/05/03
2			
3			
4			
5			
6			
7			
8			
9			
10			
11			
12			

1. Description.

This product is a AC TO DC power transfer device ,it can provide for a **5.4W** (12V DC **450mA**) single DC output with constant voltage source, it covers all the related electrical, mechanical, environmental and safety aspects.



2. Electrical.

2.1 Input Voltage (AC) :

- a. From **100- 240Vac** Nominal.
- b. From **90 - 264Vac** Maximum.

2.2 Input Frequency Range

47 Hz(min) ~ **63 Hz**(max)

2.3 Input In-rush Current.

50A Max at Cold start@25°C , AC input **220V** and dc output full-loading.

2.4 Input Current.

- a. **0.2A** Max at 90V ac
- b. **0.15A** Max at 264V ac

2.5 Hold-Up time.

7mS minimum at dc output full loading and 115 Vac 50/60Hz input.

2.6 Input wattage at output no-load / minimum-load condition.

Less than **0.15W** Pin DC output load and 240Vac input voltage and frequency condition.

2.7 Efficiency.

75% minimum at dc output full loading and 115/230Vac input voltage range included dc output cable voltage drop loss.

2.8 Safety Test.

- a. Leakage current less than **0.25mA** at 264Vac, 50Hz.
- b. Hi-Pot test : **3000Vac**, **10mA**, **3Sec** between Primary to Secondary ground.
- c. Insulation : at dc **500Vdc**, **1 Sec** between Primary to Secondary circuit,
IR shall \geq **50M Ω**

2.9 Output Voltage and Current (DC).

V/out	V/range	I /out(Nominal)	I/out(max)10Sec
12.0V	11.4—12.6	0.45A	0.5A

2.10 Ripple and Noise.

Low frequency ripple (< 100KHz) \leq 100mVpp, and Total composite Ripple and Noise. Less than 120mVpp, tested by dc loading side parallel with a 10uF/EC(C2) and 0.1uF/Ceramic(C1). Capacitors and Measured Band-Width with DC-20MHz.

2.11 Over-Shoot and under-shoot.

Less than 10% of nominal Voltage value.

- a. 0.6A (the condition of 100Vac input)
- b. 0.7A (the condition of 240Vac input)

2.12 Protection.

- a. SCP: For short circuited protection and with auto-recovery function.

2.13 Rise time.

The output voltage should rise from 10%~90% volt and settle within regulation in less than 20 msec from apply of AC input voltage condition.

2.14 Output voltage Temperature Coeffience.

Less than 0.5%/C.

3. Environment.

3.1 Temperature

- a. Operation : -20 to 50 °C
- b. Storage : -30 to 80 °C

3.2 Humidity

- a. Operation : 10 to 95%
- b. Storage : 10 to 95%

3.3 Altitude.

From sea level to 10,000Ft (operation) and 40,000Ft (Non operation)



4. EMC.

4.1 AC/DC Converter surrounding circuit (I) – For EMC

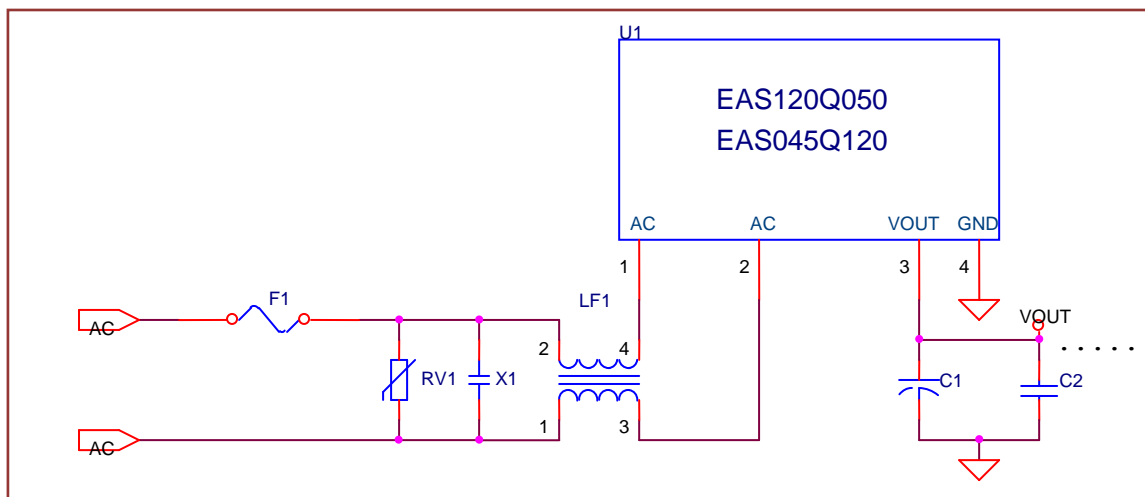

NO.	PART		NOTE
F1	AP5, 250V, 0.5A	ALPY FUSE	Use same or under 0.5A
RV1	INR, 10D391, 390V	Bourns Inc.	
X1	0.1uF, 275VAC, X2 CAP, MPX.	CARLI	
LF1	LF1020S-502-0.4A, 5mH	HANAM	Over 0.3A, 0.5mH ~ 20mH
C1	100uF, 16V, Electrolysis	SAMYUNG	Max 100uF
C2	0.1uF, 16V, MLCC	SAMSUNG	

5. Reliability.

Referring Standards	Specification
EN61558	EN61558-1:22005+A1:2009 EN61558-2-16:2009+A1:2013

5.1 .Life.

- Average life expectancy of 5 years. $8(H) \times 300(D) \times 5(Y)$.
- Environment Ambient: 25°C

5.2. M.T.B.F.

30,000 Power On Hours at 25°C

5.3 Temperature Rise.

Less than 45°C at nominal AC input / DC output full loading and environment temperature 25+/-1°C on Top/Bottom of plastic case.

5.4. Burn-in.

100% Burn-In with 80~100% loading & 35~45°C Environment temperature .

5.5. Vibration Test.

- a. Non operation vibration with shipping container shall be 2G'S peak, 7-50Hz, 4G'S peak 50-500Hz, after test no abnormally to be found.
- b. Operation vibration shall be 0.5G'S peak, 10-60Hz, 3 Axes, after test no abnormally to be noted.

5.6. Drop-Test.

The product to be dropped from 1000mm height onto a concrete floor covered with 20mm vinyl tile one times from 3 different surface(X-Y-Z),after test, the switching power supply is not broken, disassembled, or damaged to access hazardous parts.

6. MECHANICAL CHARACTERISTICS.

6.1 Dimension: 35.99mm(L) * 16.99mm(W) * 25.0mm(H) Weight : 17gram

6.2 AC Inlet: 2 IN plug.

6.3 Case Material: NORYL (PC,PC+ABS,or equivalent),94V-0, Color;Black

7. OUTLINE DIMENSIONS(Unit:mm).

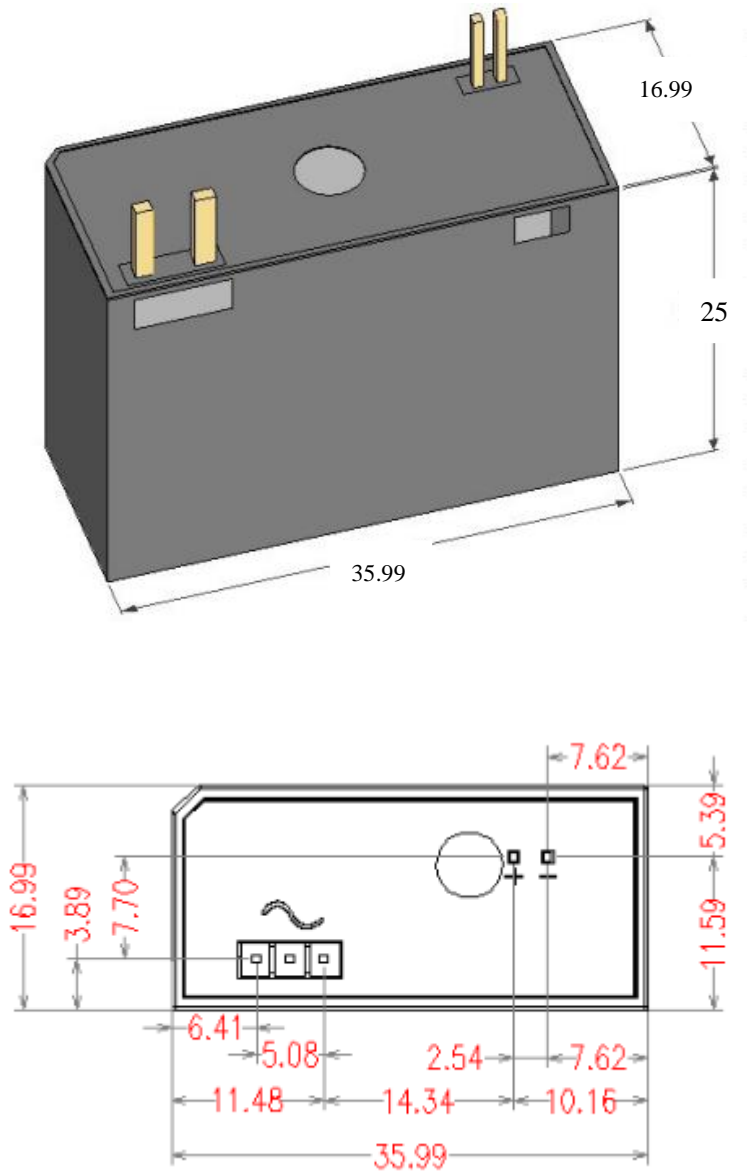

- NOTE: 1. Case cover & chassis material **PC: BLACK**
2. AC PIN MATERIAL: BRASS (NI PLATED)
3. Tolerance: **±0.2**
4. PIN Size : 0.6mm X 0.6mm (MAX 0.8mm)
5. Case cover: NO company LOGO

8.LABEL DIAGRAM.

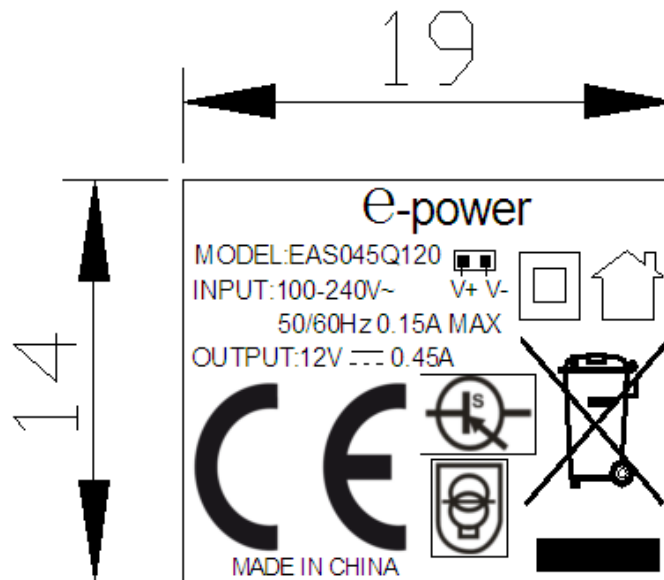

- Note:**
1. MATERIAL: POLYESTER+PVC; COATING: 0.25+-0.05mm
 2. SILVER characters BLACK background
 3. LEAD FRE
 4. Tolerance: ± 0.1

9. Packing Drawing(Unit: mm).

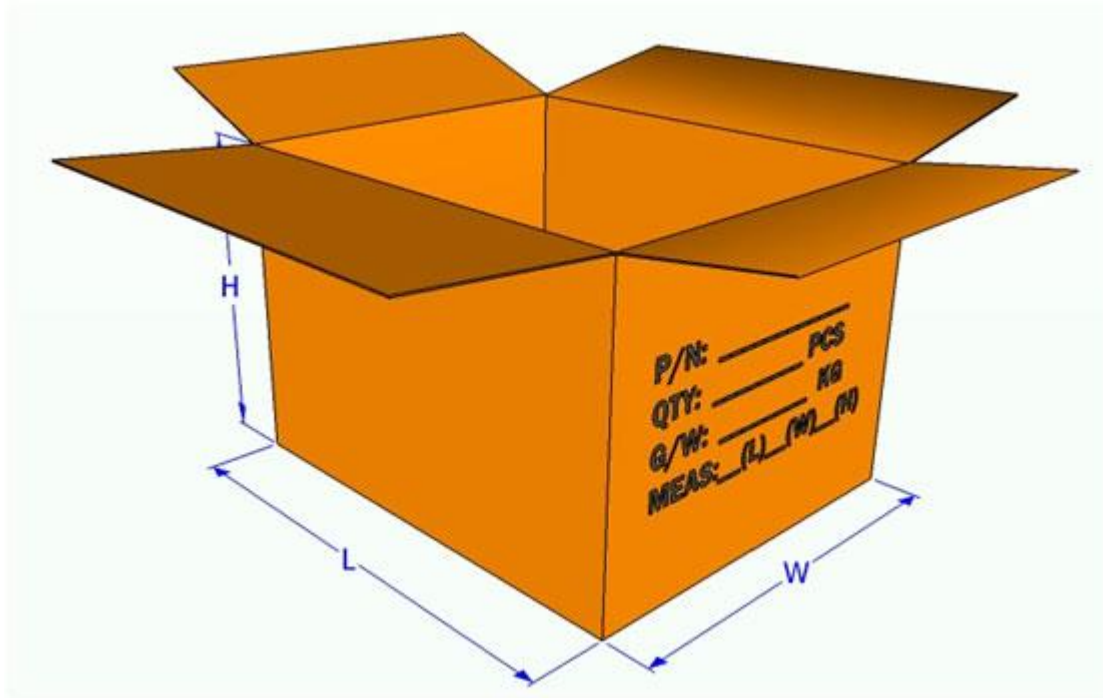

Outer Carton: Dimensions (L*W*H): 500*400*200mm Q'ty: 756PCS