

Specification for approval

规格（承认）书

※ PARTNO (型号): S-3261CSR

※ STATEMENT (说明): _____

※ ACCEESSORY (附件):

1、

2、

3、

※ CUSTOMER' S PROPOSAL (顾客意见栏):

☆ AGREE (同意)

☆ DIS AGREE (不同意)

※ CUSTOMER SIGNATURE:

(顾客确认签字): _____

DRAWING NO. :

DATE:

Page: 1

PACKAGE DIMENSIONS(外形尺寸)

0.36"

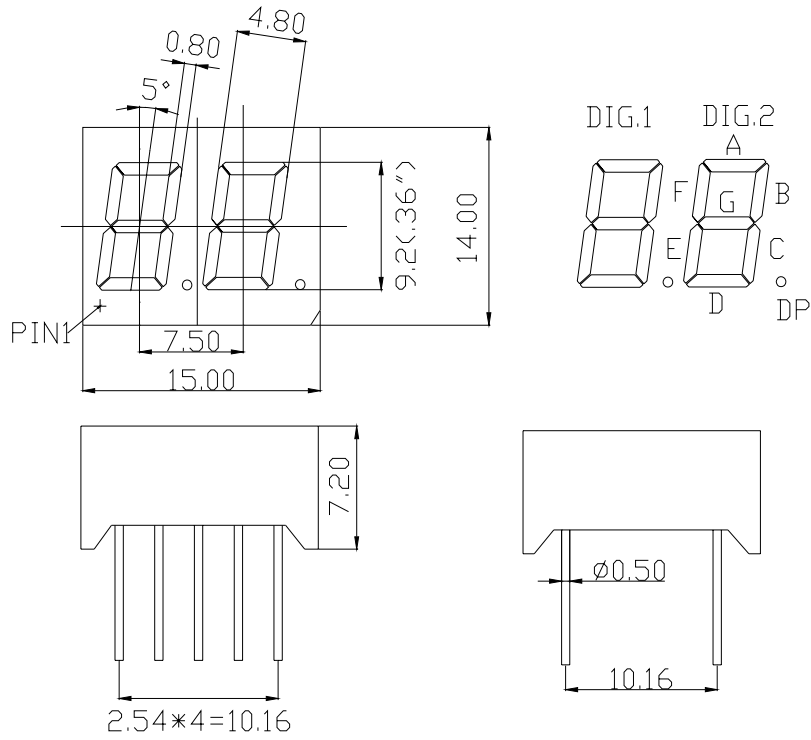

S-3261CSR

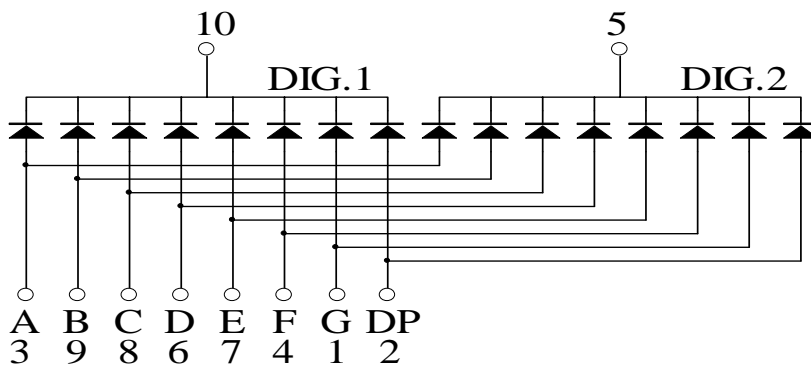

DRAWING NO. :

DATE:

Page: 2

1. ELECTRO—OPTICAL CHARACTERISTICS 光电特性: (Ta=25°C)

SYMBOL 符号	PARAMETER 项目	TEST CONDITION 测试条件	TYP 标准值	MAX 最大值	UNIT 单位
V _F	Forward Voltage, Per Segment 正向压降	I _F =20mA	1.8	2.2	V
I _R	Reverse Current, Per Segment 反向漏电流	V _R =5V		50	uA
λ _p	Peak Emission Wavelength 峰值波长	I _F =20mA	660		nm

2. ABSOLUTE MAXIMUM RATING 其他参数: (Ta=25°C)

SYMBOL 符号	PARAMETER 项目	RED 高亮红	UNIT 单位
PAD	Power Dissipation Per Segment 功耗	100	mw
V _R	Reverse Voltage Per Segment 反向耐压	5	V
I _{AF}	Continuous Forward Current Per Segment 最大使用电流	30	mA
I _{PE}	Peak Forward Current Per Segment (Duty=0.1, 1KHz) 最大峰值电流	200	mA
---	Derating Linear From 25°C Per Segment 温度系数	0.5	mA/°C
T _{OPr}	Operating Temperature Range 工作温度	-25°C to +85°C	
T _{stg}	Storage Temperature Range 贮藏温度	-25°C to +85°C	
Solder Temperature 1/16 inch Below Seating Plane 3 Seconds at 250°C 焊接温度 230°C/5 秒 离管座 1.6mm 以上			

DRAWING NO. :

DATE:

Page: 3