

**MAGNETIC SENSOR BURGLAR ALARM**  
CODE 506 **LEVEL 1**

This set of theft proof circuit is a very small set with complete efficiency including time detention with warning sound with selective function either with time detection or without time detention, and able to set the warning time.

**Technical specifications:**

- power supply : 9VDC.
- consumption : 40mA. max.
- PCB dimensions : 3.27 x 1.57 inches.

**How to works:**

After power supply to the circuit C2 will store power through R3, at this time the warning circuit will not work either the switch on or off, when C2 charges power up to 2/3 of the power supply, the pin13 of IC1/2 will also obtain power supply. At that moment the set is not working, but after we switch on the magnet switch, the pin12 will obtain high power, at pin11 will be low power, pin10 will feed back high power to pin12 in order to make IC1/1 and IC1/2 continue working, if we side SW to position 2 it will make TR1 to TR3 working. The PIEZO will expose warning sound and if SW is at position 1, there will be no warning sound will heard from the PIEZO. If we switch off the magnet switch to same circuit, it will continue giving warning sound while C4 will discharge power through R7. Pin4 will obtain low power when C4 charges power up to 2/3 of the power supplied, the power returning short circuit through R6 ground. Pin12 and 10 will obtain low power, TR1 to TR3 stop working which makes the warning sound stop. If the magnet switch is on the warning sound will continue on.

**PCB assembly:**

Shown in Figure 3 is the assembled PCB. Starting with the lowest height components first, taking care not to short any tracks or touch the edge connector with solder. Some tracks run under components, and care should be taken not to short out these tracks. All components with axial leads should be carefully bent to fit the position on the PCB and then soldered into place. Make sure that the electrolytic capacitors are inserted the correct way around. The LED has a flat spot on the body which lines up with the line on the overlay. Now check that you really did mount them all the right way round!

**Testing:**

- 1.Slide switch 3 to supply power to the circuit. SENSOR point is for connecting to the magnet pole pointint towards each other according to the chart. The circuit is not working because position 3 is off.
- 2.Slide the switch to 2, there is no sound at the moment. Slide the moment switches 10 cm. apart, coupling them, at the moment there is no sound, wait until 15 sec. then slide the magnet switch 10 cm. apart the sound will come out through the dynamic buzzer,

couple the magnet switches as before the sound will be on for 1 min. after that it will go off automatic.

3.Slide the switch to 1 leave it for 15 min. then slide the magnet switches 10 cm. apart then couple them as before, there is no sound at the moment, leave it 10 sec. the sound will accur and lasts for 1 min. then it will automatically stop.

**Application:**

Couple the magnet switches on the door frame or window frame, if it is necessary o be apart it should not more than 5 mm., connect respectively according to the chart.

**Selecting operation:**

- 1.Position 3 is off position.
- 2.Selecting position 2, the circuit will work in case we open the door and close it immediely, the sound last for 1 min. it will automatically stop, if the door left open the sound will continue.
- 3.Selecting position 3, the circuit will not work when open or close the door, the detention is made for us to switch off first, if we do not slide the switch to 3, the sound with work after we open the door for 10 to 15 sec. and it will last for 1 min. and will automatically stop, the sound will continue in case we leave the door open.

**Figure 1. Installing the componants**

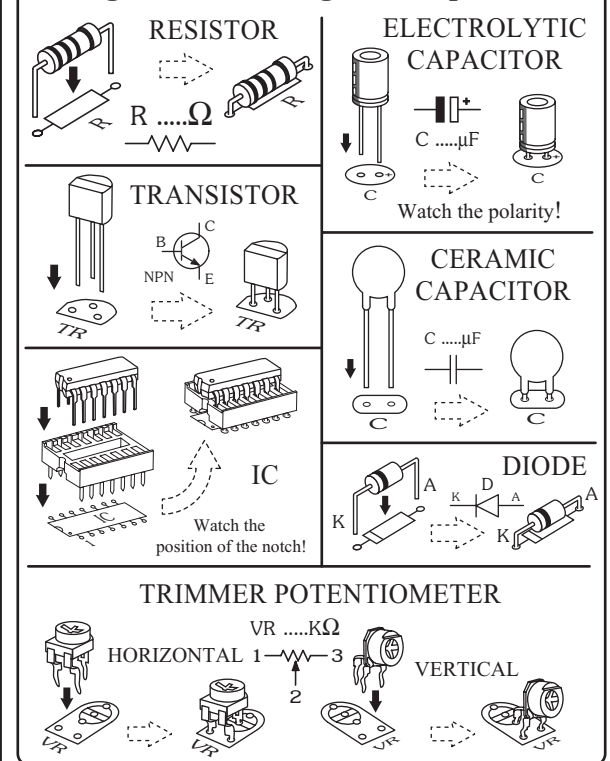

**Troubleshooting:**

The most problem like the fault soldering. Check all the soldering joint suspicious. If you discover the short track or the short soldering joint, re-solder at that point and check other the soldering joint. Check the position of all component on the PCB. See that there are no components missing or inserted in the wrong places. Make sure that all the polarised components have been soldered the right way round.

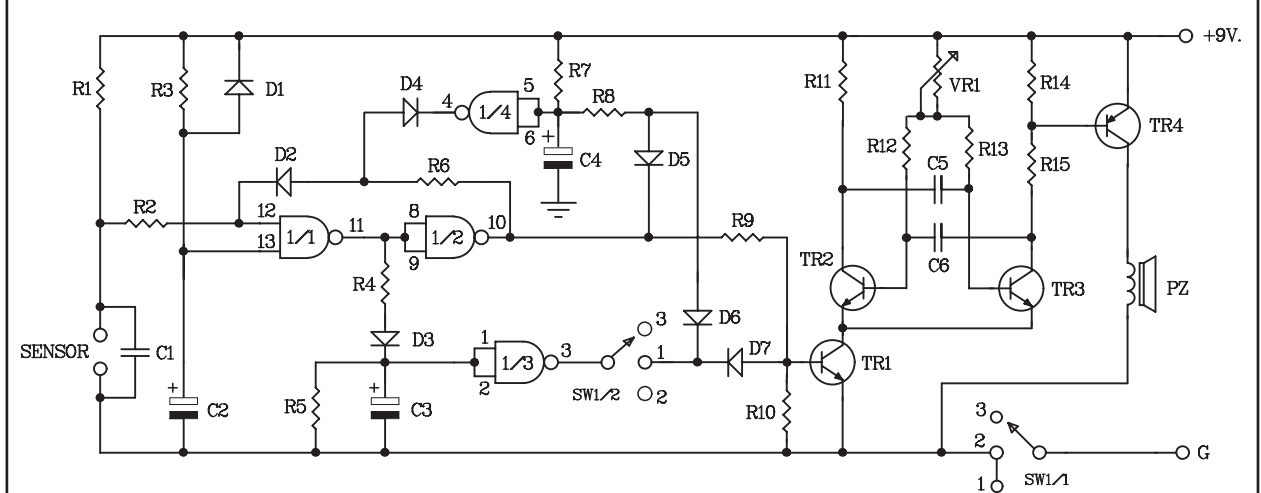

**Figure 2. The magnetic sensor burglar alarm circuit**

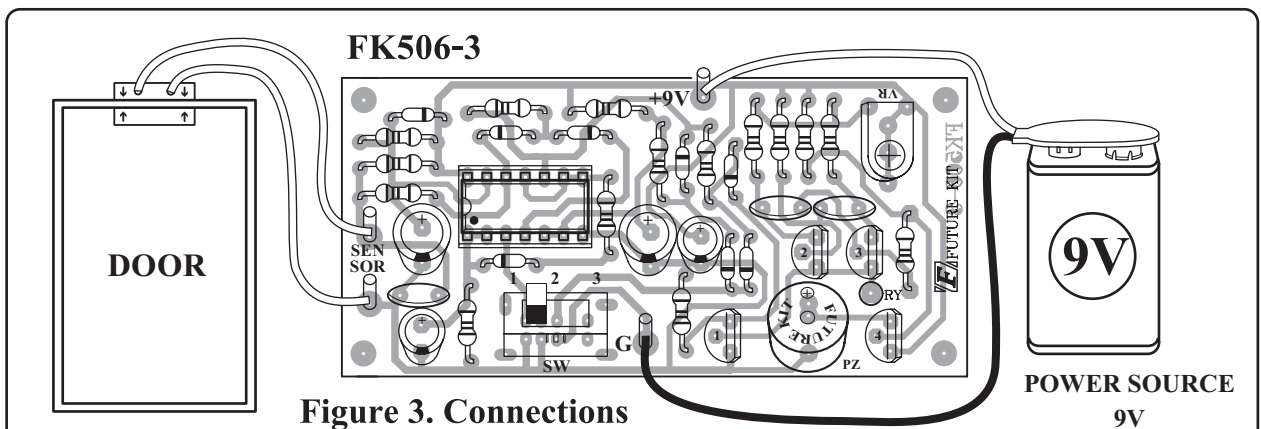

**Figure 3. Connections**

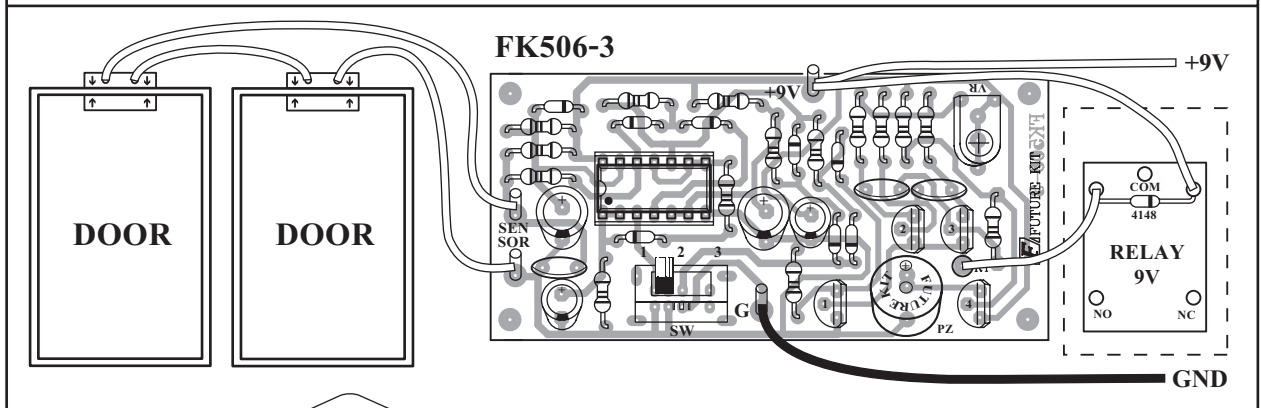

**NOTE: FUTURE BOX FB04 is suitable for this kit.**