

INFRARED REMOTE CONTROL 25' 1CH.
CODE 410 **LEVEL 2**

This infrared remote circuit can be easily used for electrical home appliances controlling.

Technical specifications:

- power supply: 9VDC.(TX), 12VDC.(RX)
- consumption: 50mA max.(TX), 65mA max.(RX)
- distance transmitter/receiver : 25ft.
- maximum load: 10A@125VAC and 5A@220VAC
- PCB dimensions : 2.02 x 1.22 inches.(TX)
3.11 x 1.68 inches.(RX)

How to works:

There are 2 major functions as per following:

TRANSMITTER : When push switch SW, IC1/1, IC1/2 and IC1/3 are created the different frequency. IC1/1 is created the low frequency 250Hz for control IC1/2 which IC1/2 will create the carrier frequency 37-41kHz. In the section IC1/4 is created the low frequency 10Hz. All frequency will be mixing by IC1/3 and transfer to TR1 for amplifying and presenting by LED infrared.

RECEIVER : The receiver module incharges for 39-41 KHz infrared wave receiving. Then will transform wave frequency of TR3 and TR4 to module "OUT". "OUT" is connecting D1 by having C3 as a filter and then transferred to TR1 and TR2 for amplifying. The collector of TR2 is connected with Flip-Flop in order to control relay. Flip-Flop comprises of TR3 and TR4 which are working one by one when receiving signal from the transmitter.

PCB assembly:

Shown in Figure 3 is the assembled PCB. Starting with the lowest height components first, taking care not to short any tracks or touch the edge connector with solder. Some tracks run under components, and care should be taken not to short out these tracks. All components with axial leads should be carefully bent to fit the position on the PCB and then soldered into place. Make sure that the electrolytic capacitors are inserted the correct way around. The LED has a flat spot on the body which lines up with the line on the overlay. Now check that you really did mount them all the right way round!

Testing:

Apply the power supply to both circuit. Adjust infrared device faces directly to the face of module. Press switching on the transmitter. LED will immediately display and relay is working. If the circuit does not work as above. Testing adjusting trimmer potentiometer at transmitter and the distance of transmitter.

Application:

Connecting "IN" point with AC voltage and "OUT" point with 220VAC home appliance. Connecting "J" point together. Functioning by pressing on for starting and pressing off for stopping. As pressing on the transmitter, relay will work and LED displays and then pressing off, relay will stop and LED will stop displaying too. If don't jump J, the circuit will be working to PUSH switch mode.

USING: For LED infrared at transmitter, you have to put the shrinkable tubing to LED infrared for control the infrared light. For MODLUE at receiver, you have to put the thick tube for protect the noise from sunlight.

Figure 1. Installing the componants

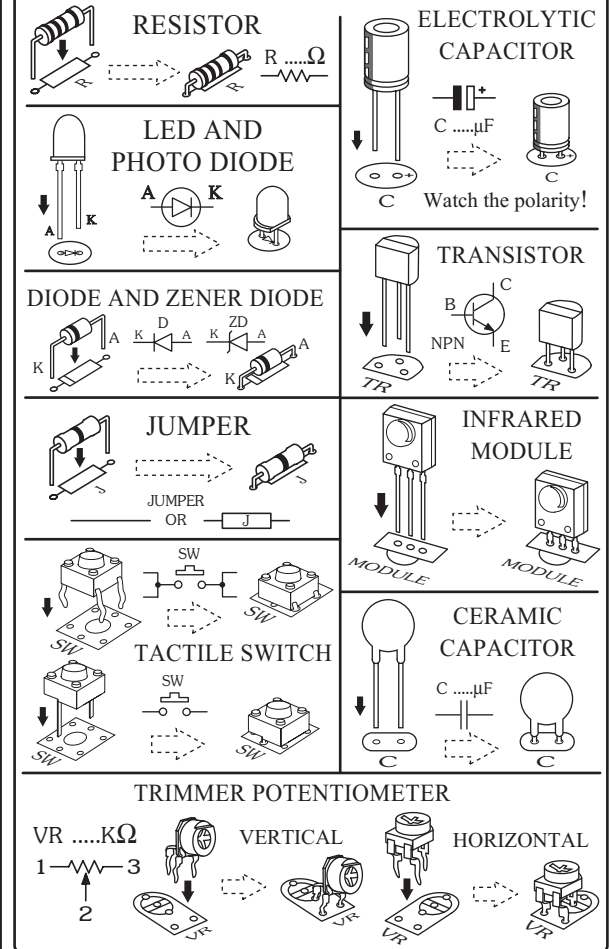

Troubleshooting:

The most problem like the fault soldering. Check all the soldering joint suspicious. If you discover the short track or the short soldering joint, re-solder at that point and check other the soldering joint. Check the position of all component on the PCB. See that there are no components missing or inserted in the wrong places. Make sure that all the polarised components have been soldered the right way round.

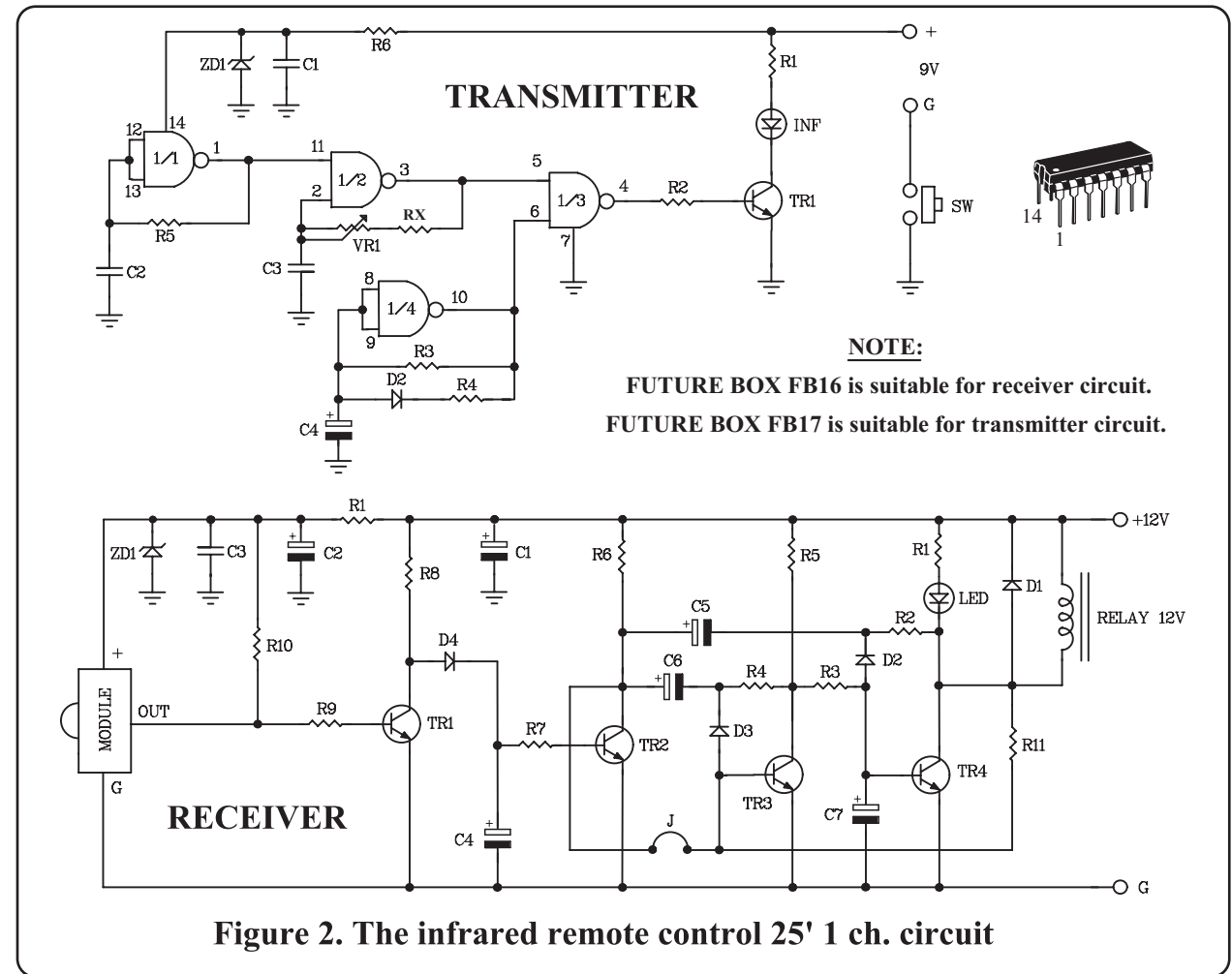

NOTE:
FUTURE BOX FB16 is suitable for receiver circuit.
FUTURE BOX FB17 is suitable for transmitter circuit.

