

WARNING LIGHT FLASHER 20 LED
CODE 179 **LEVEL 1**

A warning flasher circuit uses for light decoration and warning signs at various places. Flashing speed can be freely adjusted whether it flashes or not. Moreover, the flashing can be changed into 2 different characters.

Technical specifications:

- Power supply: 110/220VAC.
- Adjust flashing speed with trimmer potentiometer.
- Flashing character : 2 types.
- PCB dimensions : 3.34 x 3.30 in.

How to work:

The circuit is composed of 3 main parts, voltage discharging, flash controlling and LED driving.

When start supplying 220VAC to the circuit, The AC voltage will be changed to DC by diodes D1-D5. And when they have been completely changed, they will be separated into two directions. One way it will move to the flash controlling part. This AC will flow from diode D5 and pass through R4 and R5, being reduced to 12V by ZD1 and discharged to flash controlling part. Another part of AC will be discharged via bridge diode D1-D4 to LED driving part.

The working of flash controlling part will start from IC1/1 which is assembled as a generating circuit and having R9, C3, D6, D7, VR1 and VR2 to control the output frequency. This generated frequency can adjust the working of the circuit during on and off period. VR1 will adjust during off period and VR2 will do during on period.

The generated frequency from IC1/1 will be transferred to the LED driving part which having IC1/2, IC1/3, TR1 and TR2 worked alternatively. IC1/2 and IC1/3 will alternatively work due to the incoming frequency, causing TR1 and TR2 to work alternatively as well. LEDs of TR1 and TR2 sets will be lit due to the working of those two ICs.

The switch that is connected between collector pins of the two ICs, is the adjuster of LED flashing character.

Circuit assembling:

External connecting and fitting of components are shown in figure 3. It is recommended to assemble the circuit starting with a lower component i.e. diodes, resistor, electrolyte capacitors and transistors etc. Be careful while assembling and check for the matching of PCB poles and components before soldering as shown in Figure 1. Use a max. 40W. solder and soldering lead with a tin and lead ratio of 60/40 together with a

joint solution inside. Recheck the assembled circuit for your own assurance. Better using a lead sucker or a lead wire absorber in case of misplacing component to protect PCB damage.

Testing:

It is recommended to carefully handle the testing as the circuit was fed by 220VAC power supply. However, taking off the plug from power supply source is a must whenever having any adjustment.

Before supplying any voltage, move the switch to position "1" and adjust the two trimmer potentiometers extremely left. And then supply 220VAC to the circuit, LEDs will alternatively flash in steps. Pull out the plug and adjust VR1 extremely left with VR2 extremely right. Plug in and will notice that the LED off-period is shorter and on-period is longer.

When having tested the circuit with above outcome results, move the switch to position "2" and adjust the two trimmer potentiometers to extremely left. Plug in and will notice that LEDs will flash in the on and off manners in the same time.

Figure 1. Components installing

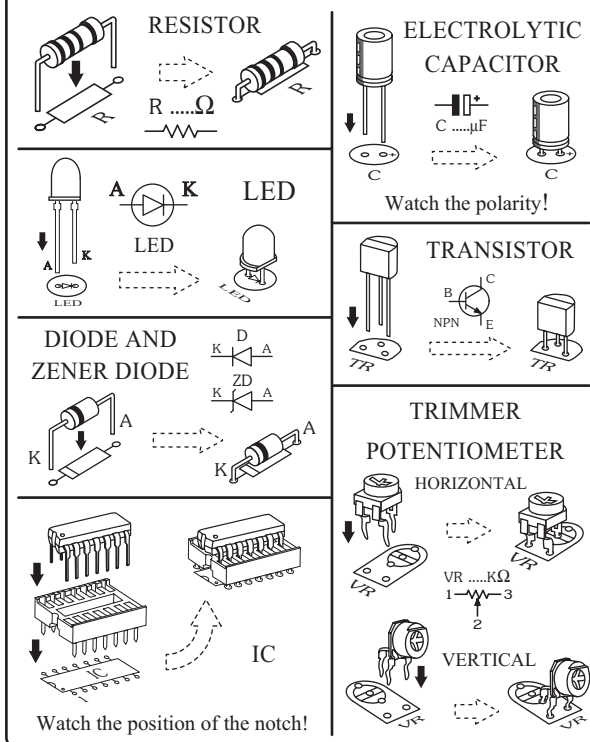

Troubleshooting:

As the circuit has only a few components, the main cause of troubles will come from component misplacing and defaulted soldering. When found out that the circuit does not work, check for the proper component placings and various soldering points.

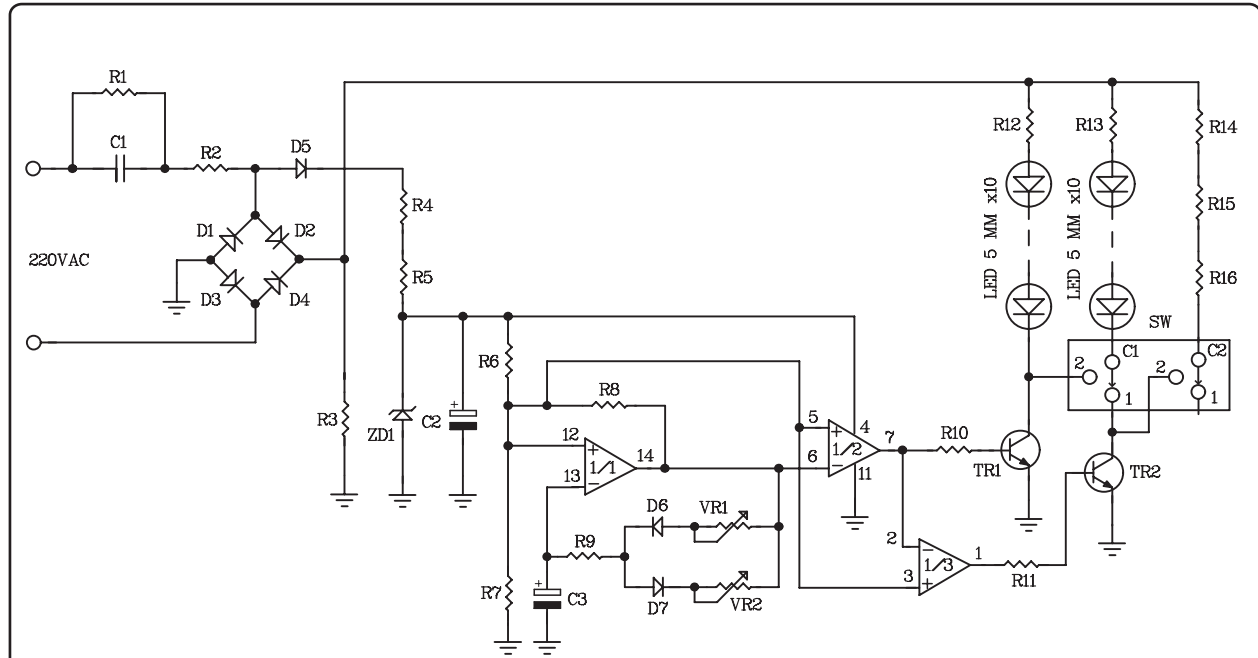
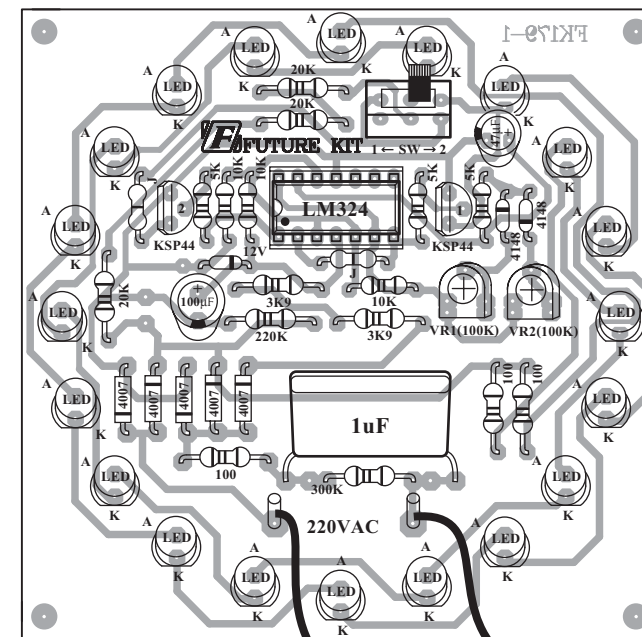
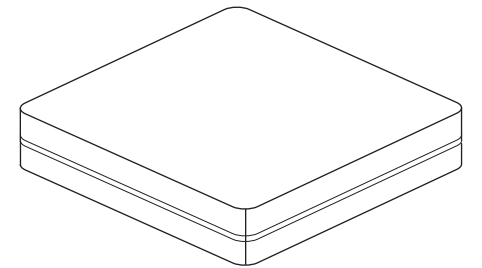

Figure 2. Warning light flasher 20 LED circuit

Figure 3. Circuit assembling



FK179-1



NOTE:
FUTURE BOX FB21
is suitable for this kit.

AC IN
220VAC

