



LED FLASHER 2 DOT
CODE 109

LEVEL 1

A basic blinking light circuit that suits those who are interested in electronics. Easy to assemble and to understand with few components and low cost. Two LEDs of the circuit will alternatively blink and the blinking speed is adjustable.

Technical specifications:

- Power supply: 9-12VDC.
- Consumption: 16-22mA max.
- Adjust flashing speed with potentiometer.
- PCB dimensions : 1.39 x 1.22 in.

How to work:

The circuit will start working from TR1 and TR2 are being assembled in the form of multi-vibrator frequency circuit. TR1 and TR2 will alternatively work. When TR1 works, LED1 will be lit up and LED2 is off. And when the TR2 works, LED2 will be lit up and LED1 is off. LED blinking speed depends upon VR, R2, R3, C1 and C2. R1 and R4 will act as a voltage reducer for LED.

Circuit connecting:

External connecting and fitting of components are shown in figure 3. It is recommended to assemble the circuit starting with a less height component i.e. diodes, resistor, electrolite capacitors and transistors etc. Be careful while assembling and check for the matching of PCB poles and components before soldering as shown in Figure 1. Use a max. 40W. solder and soldering lead with a tin and lead ratio of 60/40 together with a joint solution inside. Recheck the assembled circuit for your own confidence. Better using a lead sucker or a lead wire absorber in case of misplacing component to protect PCB damage.

Testing:

Connect the circuit to 9-12VDC power supply source. LED1 and LED2 will work alternatively. Try to adjust the trimmer potentiometer VR1, blinking speed will be varied according to the adjustment. Those above two results will show that the circuit is workable.

Figure 1. Components installation

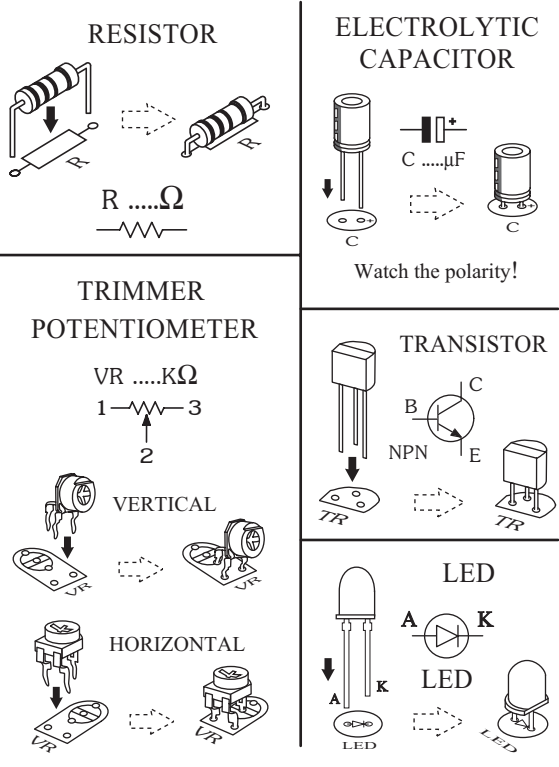

Troubleshooting:

As the circuit has only a few components, the main cause of troubles will come from misplacing component and defaulted soldering. When found out that the circuit does not work, check the placing component and various soldering points.

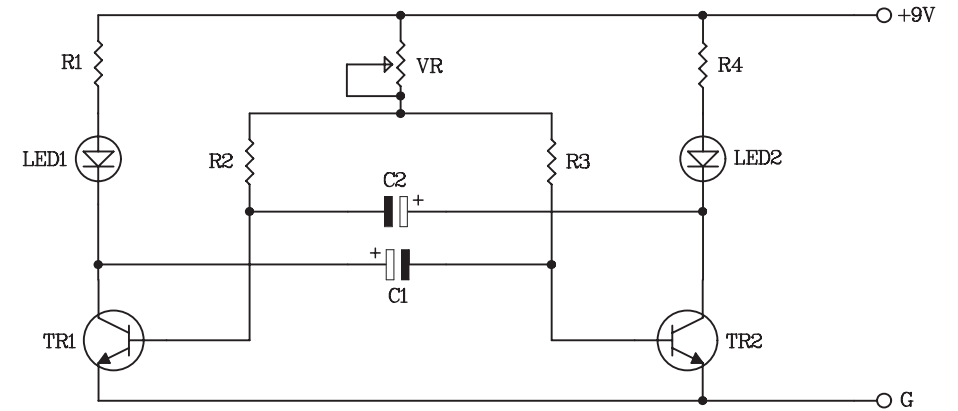
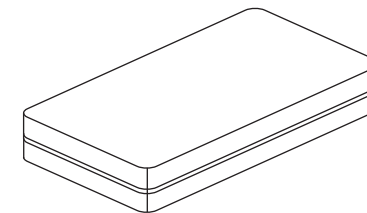
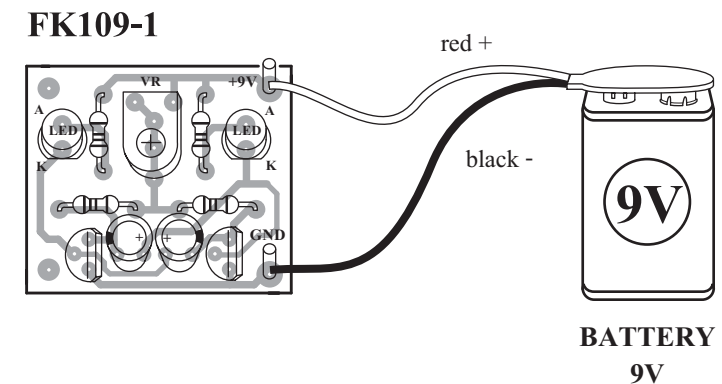

Figure 2. LED FLASHER 2 DOT circuit

Figure 3. Circuit connecting



NOTE:

FUTURE BOX FB17 is suitable for this kit.